

**VESTIL MANUFACTURING CORP.**  
2999 N. Wayne St., Angola, IN 46703  
Ph: 260-665-7586 · Fax: 260-665-1339  
E-mail: sales@vestil.com · Website: www.vestil.com

# OWNER'S MANUAL

## CART-23 & -24, ALL MODELS

Serial number \_\_\_\_\_

Operation Instructions .....	2-3	Power Unit's Operation .....	9
Routine Maintenance & Safety Checks .....	4	Troubleshooting .....	10
Exploded Power Unit Drawing & BOM .....	5-6	Safety Label Identification .....	11
Electrical & Hydraulic Diagrams .....	7-8	Warranty .....	12

### IMPORTANT NOTES, WARNINGS AND SAFETY INSTRUCTIONS

Ensure that all employees understand and follow the following.

- ☞ Failure to read and understand this owner's manual before using or servicing the cart constitutes a misuse of the product. All persons who will use or care for this product must be familiar with this material.
- The load must be removed and the platform fully lowered before any work is performed on the cart.
- Ensure that all safety and warning labels stay in place and are legible.
- Do not use the cart if any damage or unusual noise is observed.
- Always watch the platform and the load carefully when the cart is in operation.
- The cart is intended for use only on compacted, improved surfaces.
- Do not use brake fluid or jack oils in the hydraulic system. If oil is needed, use an anti-wear hydraulic oil with a viscosity grade of 150 SUS at 100°F, (ISO 32 cSt @ 40°C), or Dexron transmission fluid.
- Contact the manufacturer for any needed MSDS information.
- ◆ Do not perform any modifications to the cart without the manufacturer's approval. Failure to receive authorization for changes to the equipment could void the warranty.
- ◆ Maintenance and repairs are to be done only by personnel qualified to perform the required work. Consideration will not be given for warranty repair charges without prior written authorization by the manufacturer.

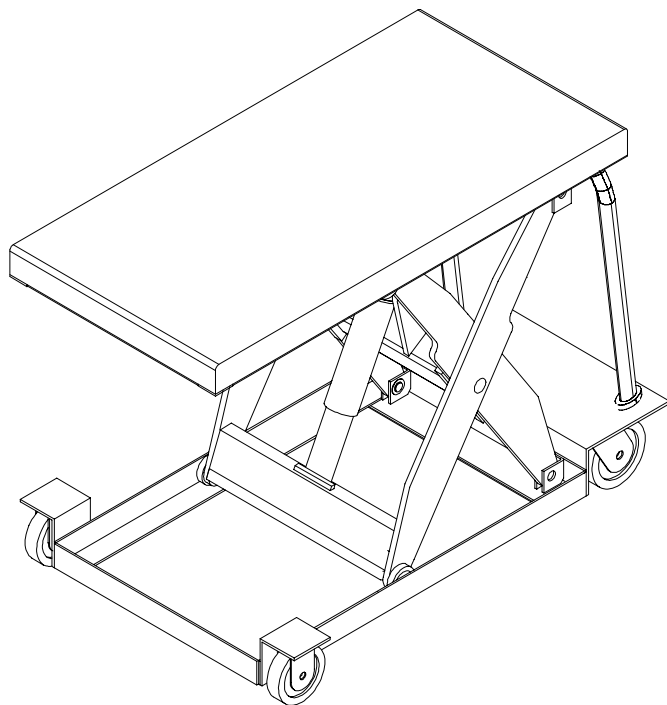

### WHEN ORDERING

#### REPLACEMENT PARTS:

We take pride in using quality parts on the equipment we manufacture. We are not responsible for equipment problems resulting from the use of unapproved replacement parts.

To order replacement or spare parts for this equipment, contact the factory.

In any communication with the factory please be prepared to provide the machine's serial number, which is indicated on the machine dataplate.

#### RECEIVING INSTRUCTIONS

Every unit is thoroughly tested and inspected prior to shipment. However, it is possible that the unit could incur damage during transit.

Inspect the unit closely when it arrives. *If you see evidence of damage or rough handling to either the packaging or to the product when it is being unloaded, immediately make a note of it on the Bill Of Lading!*

It is important that you remove the product's packaging upon its arrival to ensure that there is no concealed damage or to enable a timely claim with the carrier for freight damage.

Also verify that the product and its specifications are as ordered.

## OPERATION INSTRUCTIONS – CART-23, -24

- o *Ensure that all employees involved in the operation of this cart understand and follow these instructions!*

The standard model CART is suitable for use in most industrial and commercial locations. It is intended to be used to transport and lift stable, evenly-distributed, non-hazardous loads and containers with rigid sides having a size or footprint approximately the same size as the platform.

### Loading:

The load rating, in pounds, is shown on the machine dataplate located on the left corner of the push handle end of the platform. It indicates the net capacity of the CART with a static load that is centered and evenly distributed on the platform.

*Warning:* The platform's rollers are not captured. Therefore, do not overhang any load at the hinged end of the platform - that could cause the roller end of the platform to tip up and dump the load. For applications involving side or end edge loading, consult the factory.

*Note:* The addition of any ancillary equipment to the cart by third parties must be taken into account when determining the maximum working load to be placed on the platform.

*Warning:* Do not exceed the cart's load ratings. Injury to personnel or permanent damage to the cart could result from exceeding the listed capacity.

### Operation:

Inspect the perimeter pinch point guards' operation daily (DC units).

*Warning:* Keep all personnel clear of the machine when it is in operation. Be certain no part of any person or object is under any part of the platform before lowering the unit.

*Caution:* Always carefully watch the platform and any load on it when it is in operation.

Do not exceed a rate of two feet per second when transporting a load with the cart.

- o The standard manually-powered CART is furnished with a two-speed foot pump. Under empty or low load conditions, the pump pushes a higher volume of fluid to the cylinder and thus lifts the platform with fewer foot strokes. With a moderate to full load, the pump will automatically reduce its output in order to generate the required hydraulic pressure.

To lift the platform, simply repeatedly press the foot pump's foot treadle. To lower the platform, press the small lever at the left corner of the pump with your toe. The unit will hold its position when the lowering lever is released.

- o The standard DC-powered CART is furnished with a constant-pressure (dead-man style) pushbutton control.

Pressing the "UP" pushbutton will turn on the power unit to raise the platform. The platform will raise only while the control is pressed. Upon releasing the control, the platform will stop and hold its position.

Pressing the "DOWN" pushbutton will energize the lowering valve to allow the platform to descend by gravity (the motor does not run). Again, releasing the control will stop the platform movement, and the unit will hold its position.

*Caution:* Never use the cart if any damage or unusual noise is observed, if it is in need of repairs, or if it seems to be malfunctioning. Notify your supervisor or maintenance personnel if you notice anything out of the ordinary.

*On DC-powered units,* attempting to raise the lift when the battery is low will cause the motor relay protection to prevent the motor's operation. Adequate battery voltage is indicated by a green LED on the motor relay. See the next page for more notes regarding operation of battery-powered units.

Ensure that all safety and warning labels stay in place and are legible. Refer to the labels page in this manual.

## **ADDITIONAL INSTRUCTIONS FOR BATTERY-POWERED UNITS**

*Note: If this product has the 24V powered traction-drive option, consult that option's information for more specific details regarding the batteries and battery charger.*

### **Warning!**

- ! Working with or near lead acid batteries is dangerous. Batteries contain sulfuric acid and produce explosive gases. A battery explosion could result in loss of eyesight or serious burns.
- ! Do not smoke or allow a spark or flame near batteries. Charge batteries in locations that are clean, dry, and well ventilated. Do not lay tools or anything metallic on top of any battery. All repairs to a battery must be made by experienced and qualified personnel.
- ! When working with batteries, remove personal items such as rings, bracelets, necklaces, and watches. Batteries can produce enough energy to weld jewelry to metal, causing a severe burn.
- ! Always have fresh water and soap nearby in case battery acid contacts skin, clothing, or eyes.
- ! Operating the battery with a low battery voltage can cause premature motor contact failure.
- ! Do not expose the lift or the charger to rain or adverse conditions.
- ! Replace defective cords or wires immediately.
- ! Check the battery's water level frequently.

### **Battery Charger Operating Instructions**

Never operate the charger with either of the cables coiled. Operating a battery charger with the cord either coiled or wrapped around itself could cause the cord to overheat, melt, and cause a short-circuit or a fire.

Connection: the ribbed wire of the charger's output cord must be connected to the battery's negative (-) terminal. The non-ribbed wire (with words printed on it) must be connected to the battery's positive (+) terminal.

When properly connected, the charger will indicate the status of its output:

Flashing green LED - the charger is not seeing a good connection to the battery.

Solid yellow LED - the charger is providing charging current to the battery.

Solid green LED - the charger is maintaining a fully charged battery.

Plug the charger into a standard 115V receptacle. If an extension cord must be used, keep it as short as possible.

*Caution:* Remember to unplug the charger before moving the equipment. Failure to do so could cause damage to cords, receptacles, and other equipment.

The battery charger can be left connected to the battery indefinitely without risk of harming the battery.

### **Troubleshooting:**

If the unit does not operate, check all of the wiring connections to make sure they're both mechanically and electrically sound - specifically at the battery, the motor, and at any location a wire is connected to the chassis. Also, make sure the quick-connect plug on the end of the pendant control cord is plugged in correctly (if applicable).

A fully charged lead acid battery in good condition at room temperature should read 12.65 volts. At 11.9 volts it is considered to be fully discharged and in need of charging. When checking battery voltage, wait at least 1/2 hour after the charger has been turned off before checking the battery's voltage.

If the batteries don't seem to be taking a charge, check the charger's 115V supply circuit and the charger's output with a voltmeter. If all check okay, confirm the battery's state of charge using a hydrometer or a voltmeter.

## **ROUTINE MAINTENANCE & SAFETY CHECKS, CART-23, -24**

- *Warning: Care should be taken to identify all potential hazards and comply with applicable safety procedures before beginning work.*
- *Warning: Remove any load, raise the platform, and install maintenance props before beginning any inspections or work on the unit.*
- *Only qualified individuals trained to understand mechanical devices and their associated electrical and hydraulic circuits should attempt troubleshooting and repair of this equipment*

(A) Inspect daily for:

- 1.) Frayed wires (DC units).
- 2.) Oil leaks.
- 3.) Pinched or chafed hoses.
- 4.) Damage or structural deformation to the structural members, the cylinder brackets, etc.
- 5.) Unusual noise or binding, or evidence thereof.
- 6.) Proper functioning of all limit switches, including those on the perimeter pinch point guard (DC units).

(B) Inspect monthly for:

- 1.) The oil level. Oil should be 1" to 1½" below the reservoir's fill hole with the lift in the fully lowered position.
- 2.) Oil leaks.
- 3.) Worn or damaged electrical wires (DC units) or hydraulic hoses.
- 4.) Pivot point wear.
- 5.) Rollers' looseness and wear.
- 6.) Integrity of the retaining hardware on all rollers and on all pivot point pins.
- 7.) Looseness, wear, or damage to the casters' bearings, mounting hardware, or surface material.
- 8.) Proper water level in the battery (DC units only.)
- 9.) Unusual noises.
- 10.) All the information, safety, and warning labels being in place and in good condition.
- 11.) The need to clean off dirt and debris.

(C) Yearly inspection

The oil should be changed if the oil darkens, becomes gritty, or turns a milky color (indicating the presence of water). Replace with an anti-wear hydraulic oil with a viscosity grade of 150 SUS at 100°F, (ISO 32 at 40°C). Ex: AW 32 or HO 150 hydraulic oil, or a non-synthetic transmission fluid. You may use a synthetic transmission fluid if you flush the system with the synthetic fluid before filling the reservoir.

# MODULAR POWER UNIT PARTS BREAKDOWN -- DC-1

- Note: Motors, cylinders, and pumps can vary by model. Consult the manufacturer to determine the exact part numbers for these items.

REV.	ENG.#	REV.	ECR #	DATE	REVISIONS	INITIAL
	073003JY-1A					

ITEM	REQ	PART NO.	DESCRIPTION
1	1	4JY1119	BASE
2	1	1212SR	BATTERY CHARGER
3	1	01-033-024	18/3 W4 PIN PLUG
4	4	37927	TINNERMAN CLIP
5	1	99-023-001	RESERVOIR
6	1	99-034-013	BATTERY STRAP
7	1	24DC36	BATTERY
8	1	BV-48	BREATHER
9	1	15-533-013	CABLE, BATTERY 23" BLACK
10	1	15-533-014	CABLE, BATTERY 23" RED
11	2	23305	SHCS UTILITY GRADE
	2	33688	HIGH COLLAR LOCK WASHER
	2	33008	USS FLAT WASHER Z PLATED
12	1	99-135-011	MOTOR, 12VDC
13	1	15-022-004	RELAY, START SOLENOID
14	1	HS64	CLAMP, WORM GEAR
15	1	BG-12V	GAUGE, BATTERY INDICATOR
16	3	ZB2BZ009	BASE, CONTACT BLOCK
17	3	ZB2BE101	CONTACT BLOCK N.O.
18	2	ZB2BA2C	OPERTOR, BLACK, NON-ILLUM.
19	1		KEY SWITCH, 2 POSITION
20	1	01-134-007	LEGEND, ON - OFF
21	1	091802JY	FIBERGLASS COVER
22	1	HS52	CLAMP, WORM GEAR
23	1	01-143-906	PUMP
24	1	01-627-010	MANIFOLD ASSM (SEE PAGE 2)
25	2	29201	TPHMS, Z PLATED
26	2	29185	TPHMS, Z PLATED
27	4	23255	SHCS UTILITY GRADE
	4	33687	HIGH COLLAR LOCK WASHER
28	1	152400-03	MOLDED CORD
29	1	150CCTM.OEM	CONNECTOR, CHARGE
30	10"	3MT ST3540	1"HOOK&LOOPPRESS SENSITIVE

REMOVE ALL BURRS AND SHARP EDGES		
CONCENTRIC	.006 TIR	.040 TIR
ANGLES	+/- .0°30'	+/- 1°0'
DECIMALS	xxx +/- .005	xxx +/- .010
	xx +/- .025	+/- .015
FRACTIONS	+/- 1/32	+/- 1/16
TOLERANCE	MACHINE	WELDMENT

## T & S EQUIPMENT COMPANY

SCALE: NTS      APPROVED BY:      DRAWN BY: J.YOUNG

DATE: 07/30/03      SIZE: A

### DC MODULAR POWER UNIT

MATERIAL:      DRAWING NUMBER: 073003JY-1A      REV:

THIS PRINT IS CONFIDENTIAL AND IS THE PROPERTY OF T & S EQUIPMENT CO. THIS PRINT SHALL NOT BE USED, COPIED OR REPRODUCED IN WHOLE OR IN PART NOR SHALL THE CONTENTS BE REVEALED ANY MANNER TO ANYONE UNLESS WRITTEN PERMISSION IS OBTAINED FROM T & S EQUIPMENT CO.



### ELECTRICAL DIAGRAM -- MODULAR POWER UNIT

- o *Warning: Care should be taken to identify all potential hazards and comply with applicable safety procedures before beginning work. Fully lower or secure the forks, and ensure that all system pressure and power have been removed, before attempting to work on the electrical or hydraulic systems.*
- o *Fully lower the forks before beginning any inspections or work on the unit.*
- o *Only qualified individuals trained to understand mechanical devices and their associated electrical and hydraulic circuits should attempt troubleshooting and repair of this equipment*

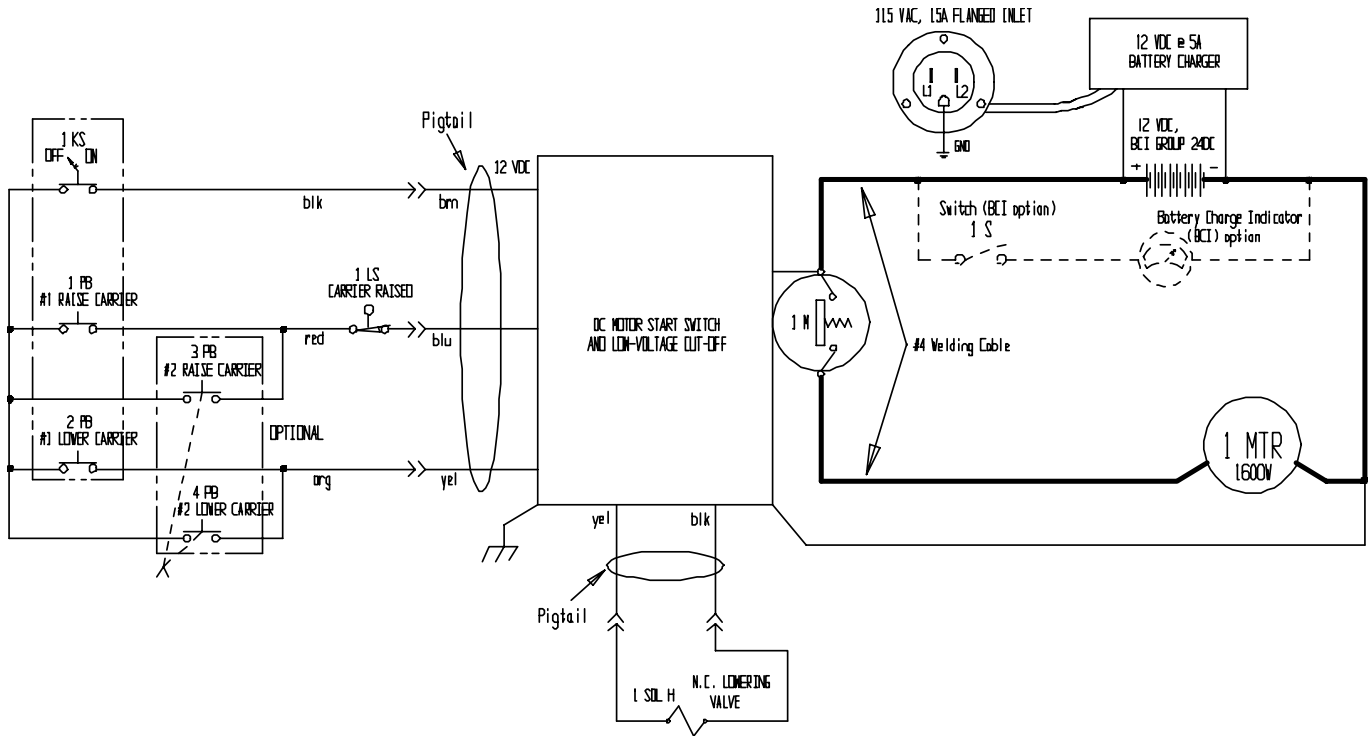

### HYDRAULIC DIAGRAM – LIFT-HOLD-LOWER CIRCUITS

- *Warning: Care should be taken to identify all potential hazards and comply with applicable safety procedures before beginning work. Fully lower or secure the forks, and ensure that all system pressure and power have been removed, before attempting to work on the electrical or hydraulic systems.*
- *Fully lower the unit before beginning any inspections or work.*
- *Only qualified individuals trained to understand mechanical devices and their associated electrical and hydraulic circuits should attempt troubleshooting and repair of this equipment*
- *Caution: Do not use brake fluid or jack oils in the hydraulic system. If oil is needed, use an anti-wear hydraulic oil with a viscosity of 150 SUS at 100°F (ISO 32 @ 40°C), or non-synthetic transmission fluid.*

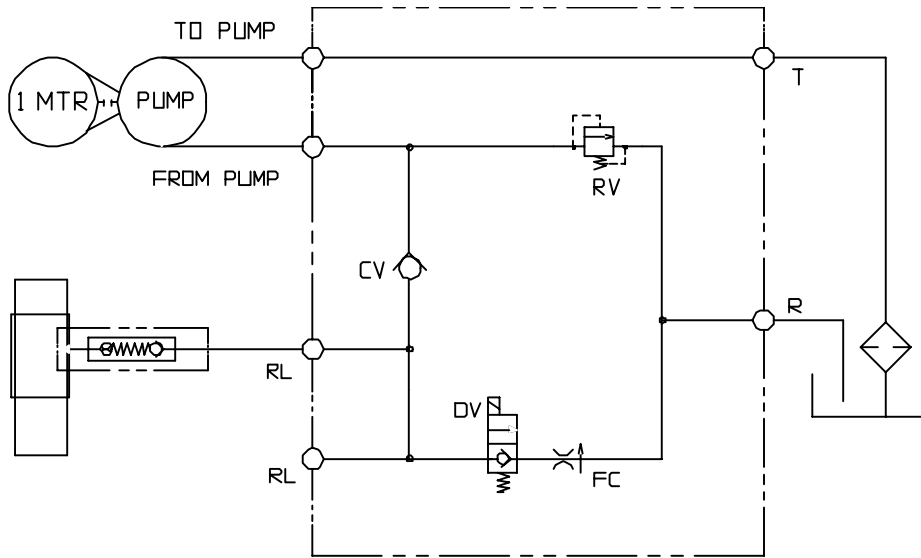

GEAR PUMP HYDRAULIC LOGIC DIAGRAM

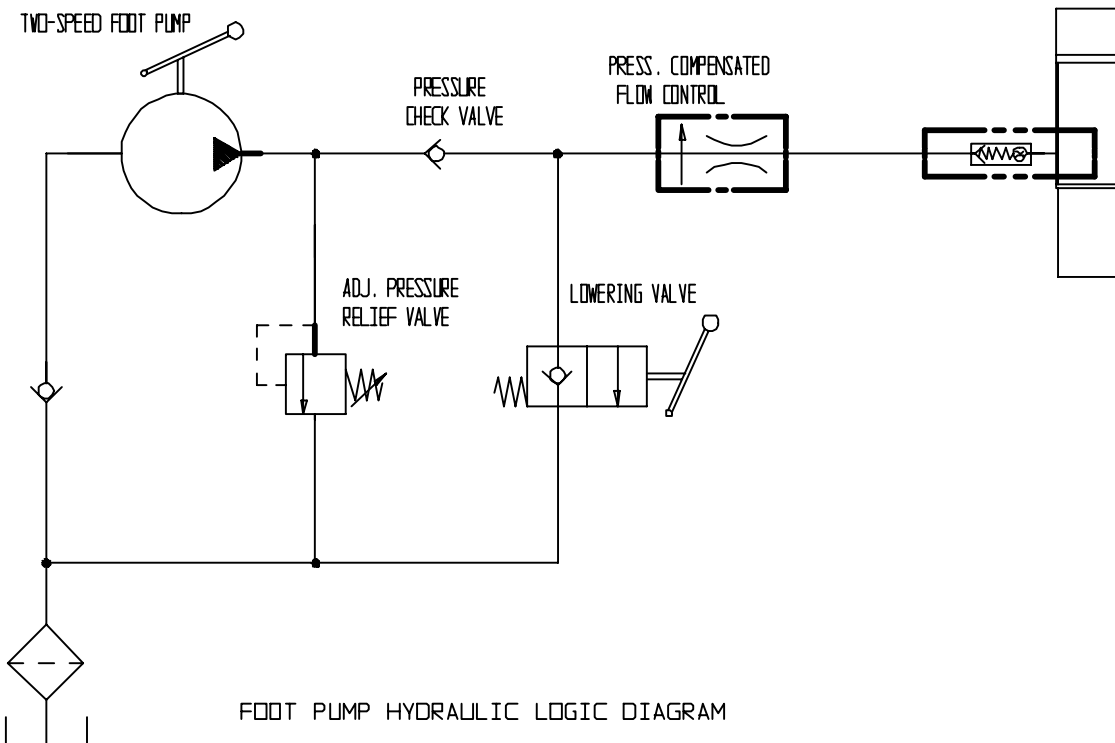

FOOT PUMP HYDRAULIC LOGIC DIAGRAM



## THE POWER UNIT'S OPERATION – CART-23, -24

The electric / hydraulic scissor lift utilizes an electric motor directly coupled to a gear-type hydraulic pump to produce the needed fluid pressure and flow to allow the cylinders to perform the work of lifting the platform load.

A hydraulic manifold houses the hydraulic control components, and is bolted directly onto the gear pump.

The power unit's hydraulic components are all rated for 3,000 psi working pressure.

↗ Important parts of the power unit include:

- The electric motor. Operates on a 12 VDC battery.
- The gear pump. Its shaft is coupled directly to the shaft of the electric motor.
- The check valve. Its purpose is to prevent the backflow of fluid through the pump. In this way it allows the platform to be held at a given elevation indefinitely.
- The pressure relief valve. Its job is to open a path for fluid to flow back to the reservoir in the event that the fluid pressure built up by the pump exceeds 3,000 psi.
- The lowering solenoid valve. This is an electrically-operated cartridge valve. It contains a screen to keep contaminants from entering the valve.
- The pressure-compensated flow control spool. This rests under the lowering valve, and regulates the fluid flow back to the reservoir when the valve opens. It allows the table to always lower at the same rate regardless of whether there is a load on the platform or not.
- The hydraulic lift cylinder(s). These are single-acting cylinders.
- The safety velocity fuse. This is a device that is installed in the cylinder's hose port. It closes quickly in the event of a catastrophic hose failure to prevent the lift from collapsing down. The platform remains stationary until pressure is reapplied to the system.
- The hydraulic fluid. The system uses HO150 hydraulic fluid. Any anti-wear hydraulic fluid with an SUS viscosity of 150 - 200 at 100°F (SAE viscosity grade of 32) such as AW-32 or Dexron transmission fluid are acceptable.

When the platform is to be raised, press the "UP" pushbutton. The motor turns, which in turning spins the hydraulic gear pump. Oil is drawn from the reservoir through the suction filter and into the pump. The pump pushes the then-pressurized oil through the check valve and out to the lift cylinders.

When the platform is to be lowered, press the "DOWN" pushbutton. The lowering valve opens, bypassing the check valve and allowing the oil in the cylinders to return back to the reservoir through the return hose. The rate at which the platform lowers is regulated by the internal pressure-compensated flow spool.

↗ In the event that the platform creeps down slowly after releasing the "DOWN" control, it will be necessary to remove the lowering cartridge valve for inspection and cleaning, as follows:

- ◆ Remove any load from the platform.
  - ◆ Raise the lift and then lower the maintenance props. Guide the props into the cylinder push assembly as you lower the platform. Hold the DOWN pushbutton until the lift rests on the props.
  - ◆ Remove the nut holding the solenoid coil on the valve stem, then remove the coil, and then unscrew the valve from the manifold.
  - ◆ Inspect the valve for contaminants, and the valve's o-rings and back-up washers for cuts, tears, or other damage.
  - ◆ With the valve immersed in mineral spirits or kerosene, use a thin tool such as a small screwdriver or a small hex wrench to push the poppet in and out several times from the bottom end of the valve. The valve should move freely, about 1/16" from closed to open position. If it sticks in, the valve stem could be bent and will need to be replaced if it doesn't free up after cleaning. Blow the valve off with a compressed-air gun while again pushing the poppet in and out.
  - ◆ Inspect the bottom of the manifold's valve cavity for contaminants.
  - ◆ Again with the thin tool, press on the middle of the flow control spool located in the bottom of the cavity. It should move down and back up freely.
  - ◆ Reinstall the valve into the manifold, tightening the valve with approximately 20 lb-ft of torque.
- ↗ If the platform lowers extremely slowly, or not at all, the cylinder's velocity fuse could be closing. This can be caused by air in the hydraulic cylinders. To bleed the air from the system:
- ◆ Remove any load from the platform.
  - ◆ Raise the lift and then lower the maintenance props. Guide the props into the cylinder push assembly as you lower the platform. Hold the DOWN pushbutton until the lift rests on the props.
  - ◆ Pull the bottom of the cylinder out of the push assembly and raise the end up higher than any other part of the hydraulic system. Rotate the cylinder so the hose port is pointing up.
  - ◆ Loosen the hose fitting ½ turn, then "jog" the motor. Oil and air will sputter from the loose fitting - once no air is observed, tighten the fitting and replace the cylinder into the push assembly.

## TROUBLESHOOTING GUIDE -- CART-23, -24

*Warning: Before performing any task, always remove any load and lower the platform fully to the floor.*

*\* Check the DC notes page for troubleshooting other problems specific to battery-powered units.*

*Consult the factory for problems at time of installation, or for any problems not addressed below.*

<u>Problem:</u>	<u>Possible cause(s):</u>	<u>Action:</u>
Power unit doesn't run when "UP" button is pressed (DC units).	Upper-travel limit switch is engaged or bad. Bad motor relay coil. Battery voltage low.	Test with meter; replace if bad.  Test with meter; replace if bad. If LED on motor relay is not on, check battery voltage with meter.
Motor runs, platform doesn't move (DC units).	Control cable's connector is loose. Pump has gone bad.	Check quick-connect plug. Consult factory.
Motor hums or pump squeals, but the platform does not move, or the platform moves only slowly (DC units).	Platform overloaded.  Pressure relief opening at full pressure.	Verify that the load doesn't exceed the table's capacity. Check for structural damage or binding of the scissor legs, etc. Check for platform overload condition.
Spongy or jerky platform movement. Platform won't lower.	Excessive air in the hydraulic cylinders. Solenoid coil is bad or connector is loose (DC units). Solenoid valve or suction hose screen plugged (DC units). Physical blockage of the structure.	Bleed air per procedure described in this manual. Check with meter. Check quick-connect plug. Remove and inspect. Clean per instructions in this manual. Inspect for foreign material or objects that might block the leg set or its rollers.
Platform lowers too slowly.	Pinched hose.  Flow control spool sticking.  Velocity fuse locking (platform only slowly creeps down).	Check pressure, supply, and return hoses for kinks. Remove plug from FC port; push on flow spool to ensure it is fully pressed into the cavity. Same as for jerky platform movement.
Platform raises, then drifts down.	Contamination holding open the lowering valve or the check valve.	Remove and inspect. Clean per instructions in this manual.

# SAFETY LABEL IDENTIFICATION

\* Product safety signs or labels should be periodically inspected and cleaned by the product users as necessary to maintain good legibility for safe viewing distance -- ANSI 535.4 (10.21). Contact the manufacturer for replacement labels.

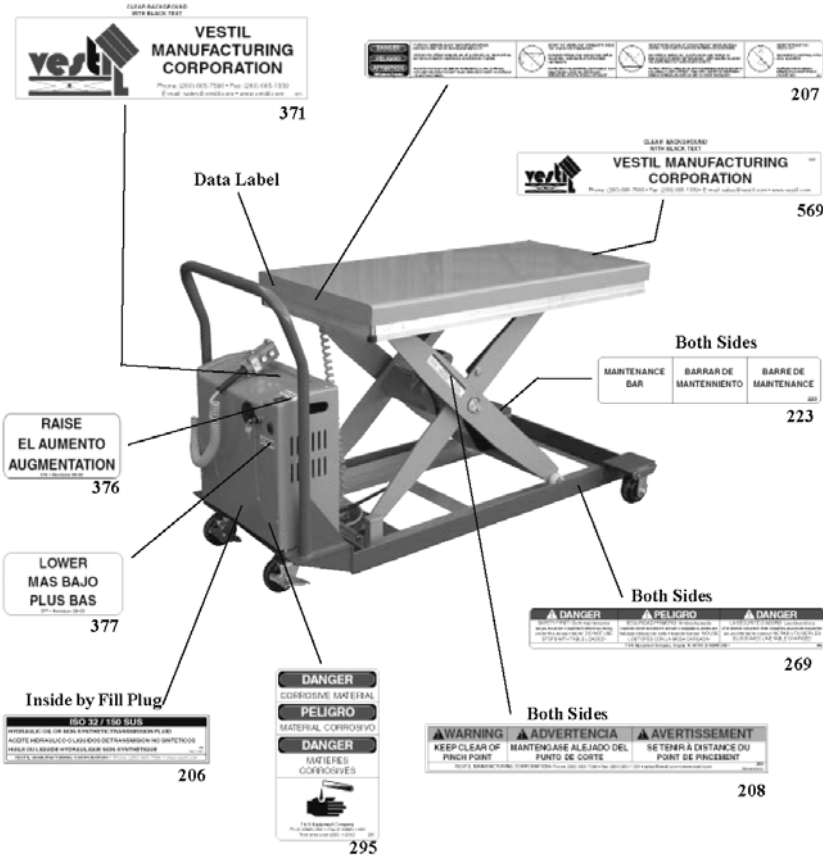

CART-2x-1x-DC

CART-2x-1x-M

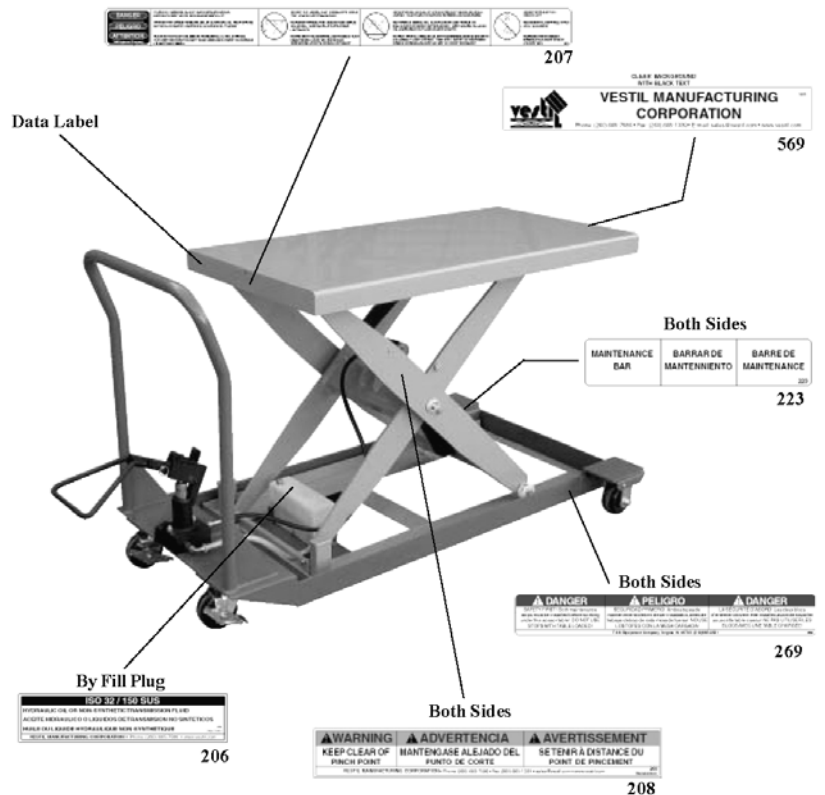

## LIMITED WARRANTY

Vestil Manufacturing Corporation ("Vestil") warrants this product to be free of defects in material and workmanship during the warranty period. Our warranty obligation is to provide a replacement for a defective original part if the part is covered by the warranty, after we receive a proper request from the warrantee (you) for warranty service.

### Who may request service?

Only a warrantee may request service. *You are a warrantee if* you purchased the product from Vestil or from an authorized distributor AND Vestil has been fully paid.

### What is an "original part"?

An original part is a part used to make the product as shipped to the warrantee.

### What is a "proper request"?

A request for warranty service is proper if Vestil receives: 1) a photocopy of the Customer Invoice that displays the shipping date; AND 2) a written request for warranty service including your name and phone number. Send requests by any of the following methods:

<u>Mail</u>	<u>Fax</u>	<u>Email</u>
Vestil Manufacturing Corporation 2999 North Wayne Street, PO Box 507 Angola, IN 46703	(260) 665-1339 <u>Phone</u> (260) 665-7586	sales@vestil.com

In the written request, list the parts believed to be defective and include the address where replacements should be delivered.

### What is covered under the warranty?

After Vestil receives your request for warranty service, an authorized representative will contact you to determine whether your claim is covered by the warranty. Before providing warranty service, Vestil may require you to send the entire product, or just the defective part or parts, to its facility in Angola, IN. The warranty covers defects in the following *original* dynamic components: motors, hydraulic pumps, electronic controllers, switches and cylinders. It also covers defects in *original* parts that wear under normal usage conditions ("wearing parts"), such as bearings, hoses, wheels, seals, brushes, and batteries.

### How long is the warranty period?

The warranty period for original components is 1 year. The warranty period begins on the date when Vestil ships the product to the warrantee. If the product was purchased from an authorized distributor, the period begins when the distributor ships the product. Vestil may extend the warranty period for products shipped from authorized distributors by *up to* 30 days to account for shipping time.

### If a defective part is covered by the warranty, what will Vestil do to correct the problem?

Vestil will provide an appropriate replacement for any *covered* part. An authorized representative of Vestil will contact you to discuss your claim.

### What is not covered by the warranty?

1. Labor;
2. Freight;
3. Occurrence of any of the following, which automatically voids the warranty:
  - Product misuse;
  - Negligent operation or repair;
  - Corrosion or use in corrosive environments;
  - Inadequate or improper maintenance;
  - Damage sustained during shipping;
  - Collisions or other incidental contacts causing damage to the product;
  - Unauthorized modifications: DO NOT modify the product IN ANY WAY without first receiving written authorization from Vestil. Modification(s) might make the product unsafe to use or might cause excessive and/or abnormal wear.

### Do any other warranties apply to the product?

Vestil Manufacturing Corp. makes no other express warranties. All implied warranties are disclaimed to the extent allowed by law. Any implied warranty not disclaimed is limited in scope to the terms of this Limited Warranty.

